



PALLET FORKS PG

Wherever the need is greatest, the load is heaviest and safety is of paramount importance, Probst Pallet Forks are the best choice for the job.

▶ Designed to transport palletised building products on vehicle loading cranes, portal cranes or construction cranes.

▶ Packs of blocks and bricks, palletised building materials can be transported and moved around easily and efficiently.

▶ The PGA's sophisticated construction will save you handling time and money. In next to no time, the height and distance between the fork tines can be adjusted to the dimensions of the goods to be lifted. The forks have a long taper for optimal engagement.

▶ A particular advantage to the PG is its light-weight construction.



▶ Depending on your requirements, we can offer pallet forks with an automatic, hydraulic or manual centre of gravity balance.

▶ High quality material components and first-class construction guarantee reliability and a long service life.

Tried and tested 1,000 times over, the powerful grabs from Probst.



PALLET FORK RANGE

All pallet forks include the following standard specifications:

- ▶ Height adjustable from 1050–1650 mm.
- ▶ Adjustable fork width from 340–1000 mm (external).
- ▶ Light-weight construction due to high-tensile steel construction.
- ▶ Various types available depending on load.

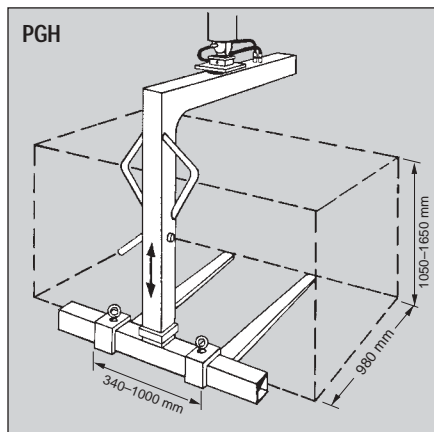
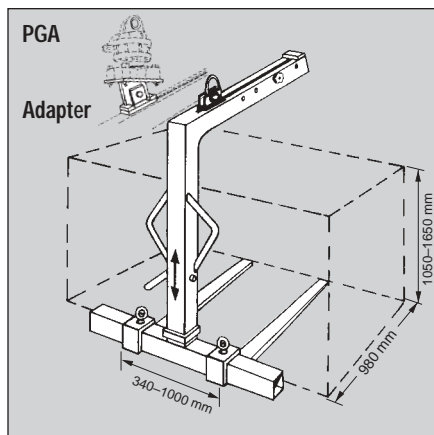
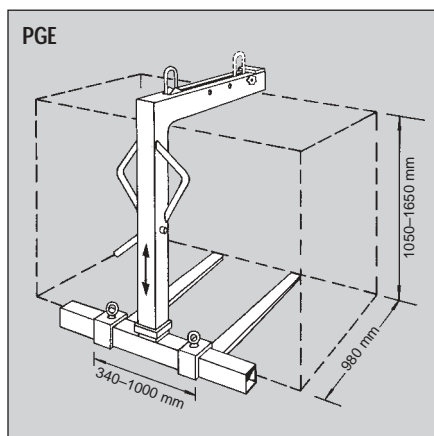

▶ Probst machinery has everything expected by true professionals. We have ruled out expensive delays caused by poor-quality parts or costly maintenance.



SAFETY FROM START TO FINISH

PGE

Manual Centre of Gravity Balance, Basic Model

▶ The crane eye is adjusted by hand according to the centre of gravity. The required height is fixed into position by means of a bolt.

| Type | Fork Measurement (mm) (in) | Carrying Capacity (kg) (lbs) at 500 mm (20" in) | Dead Weight (kg) (lbs) |
|--------|----------------------------|---|------------------------|
| PGE 15 | 100 x 40 (4 x 1 1/2") | 1,500 (3,300) | 90 (200) |
| PGE 20 | 120 x 40 (4 1/2 x 1 1/2") | 2,000 (4,400) | 115 (250) |
| PGE 25 | 100 x 45 (4 x 1 1/2") | 2,500 (5,500) | 150 (330) |
| PGE 30 | 125 x 45 (5 x 1 1/2") | 3,000 (6,600) | 180 (400) |

PGA

Automatic Centre of Gravity Balance due to spring loaded slide mounted

on maintenance free steel polyamide slide bearings.

Minimum load weight is approx. 25% of the load. The stated minimum load is necessary for the automatic centre of gravity balance to function.

| Type | Fork Dimension (mm) (in) | Carrying Capacity (kg) (lbs) at 500 mm (20" in) | Dead Weight (kg) (lbs) |
|--------|---------------------------|---|------------------------|
| PGA 15 | 100 x 40 (4 x 1 1/2") | 1,500 (3,300) | 95 (210) |
| PGA 20 | 120 x 40 (4 1/2 x 1 1/2") | 2,000 (4,400) | 120 (265) |
| PGA 25 | 100 x 45 (4 x 1 1/2") | 2,500 (5,500) | 160 (350) |
| PGA 30 | 125 x 45 (5 x 1 1/2") | 3,000 (6,600) | 180 (400) |

PGH

Hydraulic Centre of Gravity Balance

Enables the forks to tilt forwards and backwards when full or empty. Equipped with a rotator, making it a one-man machine.

▶ Equipped with standard flange plate to mount the rotator or the quick-change device.

| Type | Fork Dimension (mm) (in) | Carrying Capacity (kg) (lbs) at 500 mm (20" in) | Dead Weight (kg) (lbs) |
|--------|---------------------------|---|------------------------|
| PGH 15 | 100 x 40 (4 x 1 1/2") | 1,500 (3,300) | 120 (265) |
| PGH 20 | 120 x 40 (4 1/2 x 1 1/2") | 2,000 (4,400) | 125 (275) |

Pallet Fork with Safety Chain

For use with construction crane.

Equipped with regulation safety chain.

Can be used for construction work if the packs are completely wrapped in film or bound with metal bands.

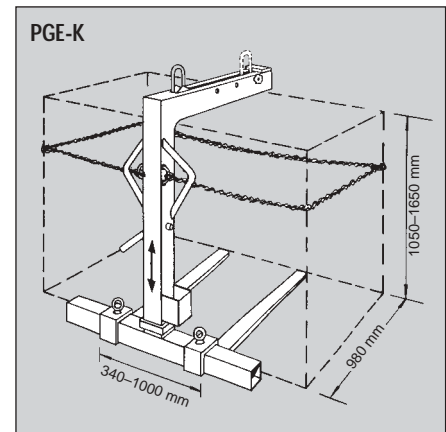

| Type | Fork Dimension (mm) (in) | Carrying Capacity (kg) (lbs) at 500 mm (20" in) | Dead Weight (kg) (lbs) |
|----------|---------------------------|---|------------------------|
| PGE 15-K | 100 x 40 (4 x 1 1/2") | 1,500 (3,300) | 90 (200) |
| PGE 20-K | 120 x 40 (4 1/2 x 1 1/2") | 2,000 (4,400) | 115 (255) |
| PGA 15-K | 100 x 40 (4 x 1 1/2") | 1,500 (3,300) | 110 (240) |
| PGA 20-K | 120 x 40 (4 1/2 x 1 1/2") | 2,000 (4,400) | 120 (265) |

See Type List for pallet forks with Safety Net or Cage.

Accessories

Quick Change Device

For PGA (with Adapter) and PGH – saves a great deal of preparation time if you have to change from grab to pallet fork after each load. The driver needs no help to operate it.

You can obtain further information and leaflets from your local Probst dealer or directly from us.