

Manhole and Cone

Installation Clamp SVZ

Especially developed for installing manholes and cones. Inside diameter 1.000 and 1.200 mm, up to 1 m height; Carrying capacity 1.300 kg.

► Economical laying process because all handling actions can be carried out by the excavator driver himself. No time consuming manual operations. The concrete elements always hang horizontally.

Manhole Suspension

Chain Clamp SRG

For transportation and installation of manhole rings and cones you can choose among five different SRG models.

- Adjustable gripping width
- Carrying capacity: 1500 and 3.000 kg.

Round Grab RG 20-80

The flexible pipe grab for fast and gentle laying of all different kinds and materials of pipes. Large adjustable opening range. Suitable for outside diameter 200 to 800 mm.

- High gripping force, automatic release. Carrying capacity: 1.500 kg



Rubber pads of the grippers avoid damage to the concrete elements.



Easy handling caused by low dead weight.



At Probst you find a wide range of all kinds of handling and laying equipment for the specific needs in earth moving and road construction. Most devices not only suited to the site operation, they also can be used for the economical handling of manhole rings, cones and pipes within the manufacturing plant. All devices are security checked and come along with the CE-certification.

PRECISE AND FAST LAYING OF MANHOLE RINGS AND PIPES

Probst grabs for manhole ring, cone and pipe installation are designed to handle the different sizes, weights, materials and surface types of manholes, cones and pipes. All devices are well designed to suit the different site conditions.

Most of them are equipped with automatic release systems to enable the excavator operator to pick up and lay the elements without the need of additional labour.

This saves time and money. Probst grabs offer the highest security and a long-term durability. The gripping elements are designed to provide the optimum gripping security, gentle material handling and long-termed durability. Coated pipes and manholes will not be damaged!



Round Grab RG

with large gripping surface to lay heavy pipes with outside diameter from 200 up to 2.500 mm.

- For weights from 1.500 to 12.000 kg.
- Ideal for work in narrow ditches.



"The best technology for safe gripping"



Efficient Pipe Laying without ifs and buts!

Manhole and Cone

Installation Clamp SVZ

The installation of manholes and cones requires a high accuracy.

Concrete manholes are produced with great precision and especially in the field of seal systems with very low tolerances. And just as they are produced, they have to be installed. Especially when the manhole rings and cones are not hanging exactly vertical, the seals can be damaged causing expensive and time wasting repairs.

PROBST offers with the patented manhole and cone installation clamp SVZ a reliable solution of the problem. The mechanical operating device is suitable for all manholes of 1000 and 1200 millimeter inside diameter as well as for asymmetrical cones of this diameters. The manhole can be picked up from the driver of the excavator by himself and transported to the place of installation. Also the release is done automatically. Each element is hanging exactly vertically – even the asymmetrical cones.

Pipe Laying Hook RLH /RLHA

For pipes up to 1 m length we offer two different RLH sizes:

Carrying capacity up to 1.000 and 3.000 kg.

Our series RLHA is suitable for pipes up to 3 m length.

- ▶ Automatic center of gravity balance.
- ▶ Adjustable stop-buffer for different pipe lengths.

Carrying capacities from 1.000 to 7.500 kg

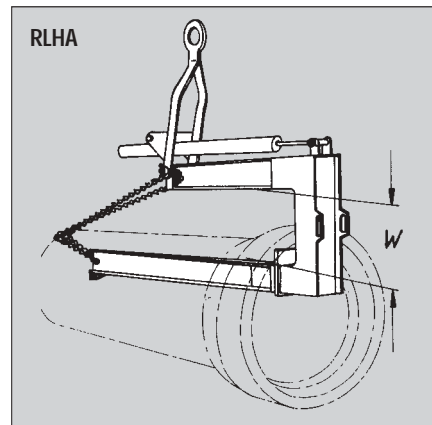

All pipe laying hooks are equipped with security chain.

Internal Transport in Manufacturing Plants

Probst offers a very wide range of suitable equipment for handling pipes, manholes and cones within the manufacturing plants, i.e. manhole insert clamp SP, manhole ring clamp RK, cone insert clamp KIG, multiple forks MFD etc.



Avoids costly waiting times during loading and unloading!



Manhole Polyp SP-H

This device for truck-cranes is suitable for inside gripping on a space-sparing and economical way to load and unload manhole rings and cones. The hydraulical pressure can be adjusted to avoid damage of the fragile products.



Manhole Ring Clamp RK I

Ideal for green and fragile concrete elements because no radial pressure is exerted during handling. Different models for different sizes available.

- ▶ Carrying capacity 2.000 kg.

You can obtain further information and leaflets from your local Probst dealer or directly from us.